

5105, 5110 SERIES

Heavy-Duty Vertical Hold Down Clamps | Product Overview

Features:

- High strength forged clamping arm for heavy-duty service
- Hardened steel pivot pins and bushings provide long life
- Black oxide finish
- Large clearance under the clamping bar
- DESTACO® Toggle Lock Plus versions available†

Applications:

- Welding fixtures
- Assembly fixtures



Covered under one or more U.S./International Patents

5105/5110
Flanged Base



5105-B/5110-B
Solid Base



5105-R/5110-R
Flanged Base
with
DESTACO®
Toggle Lock
Plus



5105-BR†/5110-BR†
Solid Base
with
DESTACO®
Toggle Lock
Plus



Technical Information

Model	Max. Holding Capacity	Clamp Bar Opening (+10°)	Handle Opening (+10°)	Weight
5105	[700lbf.] 3100N	89°	159°	[1.12lbs] 0,51kg
5105-B				[1.06lbs] 0,48kg
5105-R				[1.10lbs] 0,50kg
5105-BR†				[1.17lbs] 0,53kg
5110	[1150lbf.] 5100N	74°	138°	[2.98lbs] 1,35kg
5110-B				[2.95lbs] 1,34kg
5110-R				[3.00lbs] 1,36kg
5110-BR†				[3.02lbs] 1,37kg

† This item is available upon request.

† Toggle Lock Plus locks the handle in the closed position only.

5105, 5110 SERIES

Heavy-Duty Vertical Hold Down Clamps | Dimensions

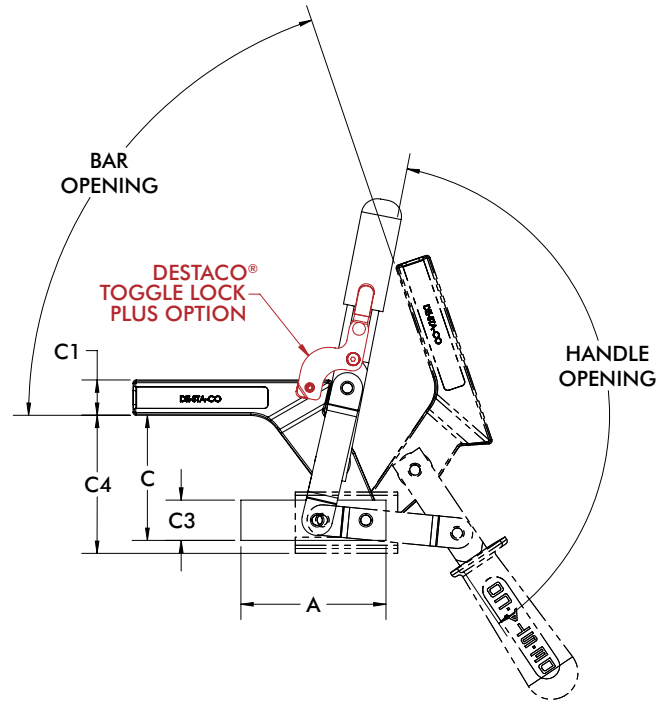
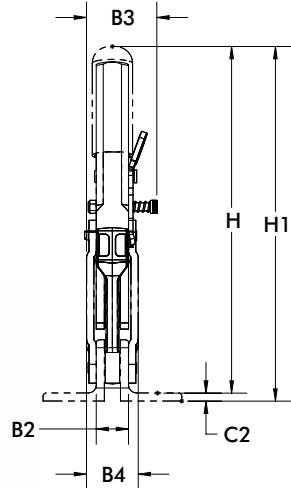

mm [INCH]
THIRD ANGLE PROJECTION

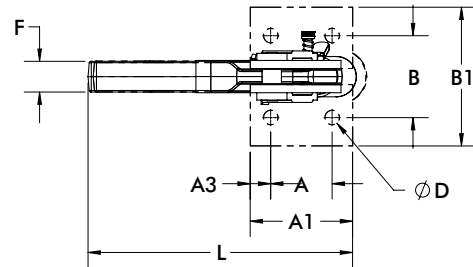

Model	A	A1	A2	B	B1	B2	B3	B4	C1	C2	C4	D	F	H1	L
5105	[1.00]	[1.62]	[0.31]	[1.46]	[2.24]	[0.59]	--	[0.98]	[0.51]	[0.16]	[2.54]	[0.26]	[0.56]	[6.54]	[4.13]
5105-R	25,4	41,2	7,9	37	57	15	[1.48] 37,5	25	13,0	4,0	64,6	6,6	14,3	166,1	104,9
5110	[1.50]	[2.50]	[0.50]	[2.00]	[2.76]	[0.79]	--	[1.26]	[0.87]	[0.20]	[3.37]	[0.35]	[0.75]	[8.70]	[6.33]
5110-R	38,1	63,5	12,7	50,8	70	20	[1.67] 42,5	32	22,0	5,0	85,6	9,0	19,1	221,1	160,9

Model	A3	B2	B3	B4	C	C1	C3	F	H
5105-B	[2.50]	[0.59]	--	[0.98]	[2.14]	[0.51]	[0.59]	[0.56]	[6.14]
5105-BR ^①	63,5	15	[1.48] 37,5	25	54,3	13,0	15,0	14,3	156,0
5110-B	[3.54]	[0.79]	--	[1.26]	[3.05]	[0.87]	[0.98]	[0.75]	[8.39]
5110-BR ^①	90	20	[1.67] 42,5	32	77,5	22,0	25,0	19,1	213,0

^① This item is available upon request

5905, 5910, 5915 SERIES

Heavy-Duty Vertical Hold Down Clamps | Product Overview

Features:

- High strength forged clamping arm for heavy-duty service
- Hardened steel pivot pins and bushings provide long life
- Black oxide finish

Applications:

- Welding fixtures
- Assembly fixtures



5905/5910/5915
Flanged Base



5905-B/5910-B/5915-B
Solid Base



Technical Information

Model	Max. Holding Capacity	Clamp Bar Opening (+10°)	Handle Opening (+10°)	Weight
5905	[750lbf.] 3340N	135°	70°	[1.08lbs] 0,49kg
5905-B				[0.82lbs] 0,37kg
5910	[1600lbf.] 7120N	132°	71°	[2.84lbs] 1,29kg
5910-B				[2.24lbs] 1,02kg
5915	[2750lbf.] 12230N	147°	74°	[6.16lbs] 2,79kg
5915-B				[5.11lbs] 2,32kg



Removable handle stop can be repositioned to limit opening angle to 90°

5905, 5910, 5915 SERIES

Heavy-Duty Vertical Hold Down Clamps | Dimensions

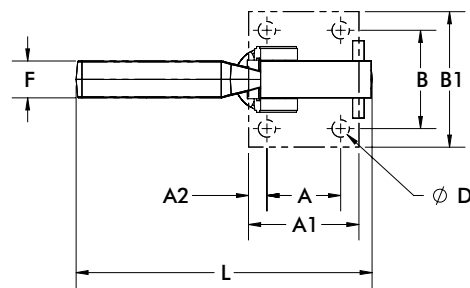
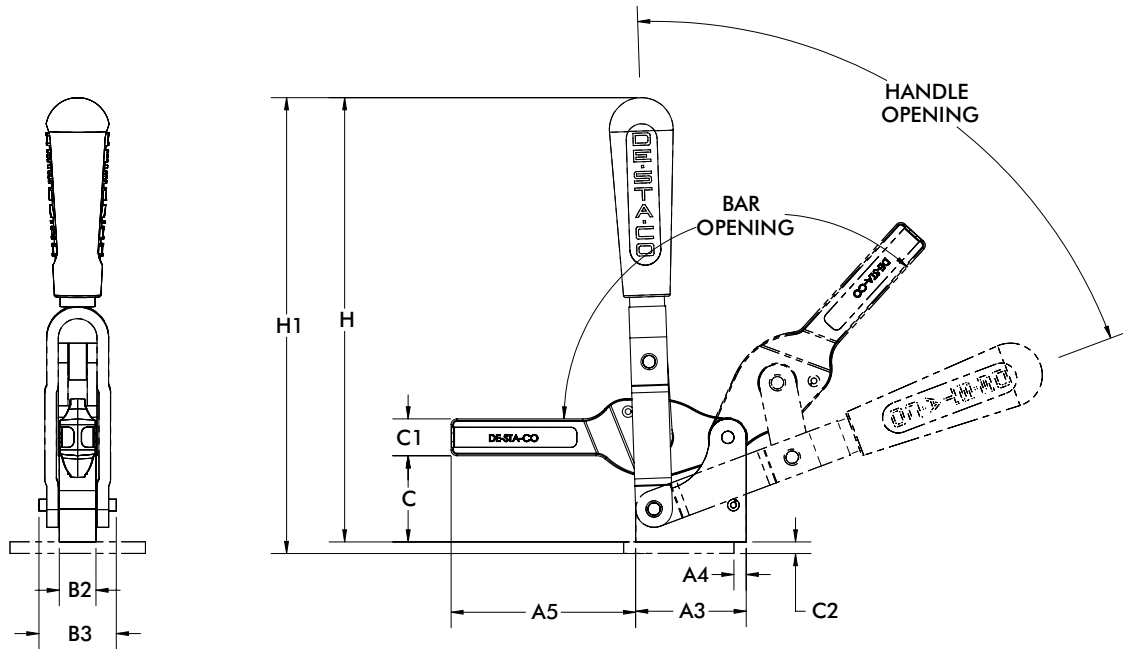

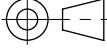
mm [INCH]

 THIRD ANGLE PROJECTION

Model	A	A1	A2	A3	A4	A5	B	B1	B2	B3	C	C1	C2	D	F	H	H1	L
5905	[1.00] 25,4	[1.50] 38,1	[0.25] 6,4	[1.51] 38,4	[0.25] 6,4	[2.49] 63,2	[1.50] 38,1	[2.13] 54,1	[0.59] 15,0	[1.02] 25,9	[1.27] 32,3	[0.51] 12,9	[0.24] 6,1	[0.29] 7,3	[0.56] 14,2	[6.51] 165,4	[6.75] 171,4	[4.02] 102.10
5910	[1.50] 38,1	[2.24] 56,9	[0.37] 9,4	[2.25] 57,2	[0.25] 6,4	[3.76] 95,5	[2.00] 50,8	[2.76] 70,1	[0.75] 19,1	[1.57] 39,9	[1.75] 44,5	[0.75] 19,1	[0.24] 6,1	[0.41] 10,5	[0.75] 19,1	[9.04] 229,5	[9.27] 235,5	[6.02] 152.88
5915	[2.00] 50,8	[2.95] 74,9	[0.48] 12,2	[2.99] 75,9	[0.38] 9,7	[5.00] 127,0	[2.75] 69,9	[3.88] 98,6	[0.98] 24,9	[1.97] 50,0	[2.37] 60,2	[1.00] 25,4	[0.35] 8,9	[0.55] 14,0	[1.00] 25,4	[10.89] 276,7	[11.25] 285,7	[7.50] 190.50

Model	A3	A5	B2	B3
5905-B	[1.51] 38,4	[2.49] 63,2	[0.59] 15,0	[1.02] 25,9
5910-B	[2.25] 57,2	[3.76] 95,5	[0.75] 19,1	[1.57] 39,9
5915-B	[2.99] 76	[4.92] 125	[0.98] 25	[1.97] 50